

**Drainage water-lifting unit
with above-floor-collection tank.**

Saniquick B100 / BT100

Conveying capacities

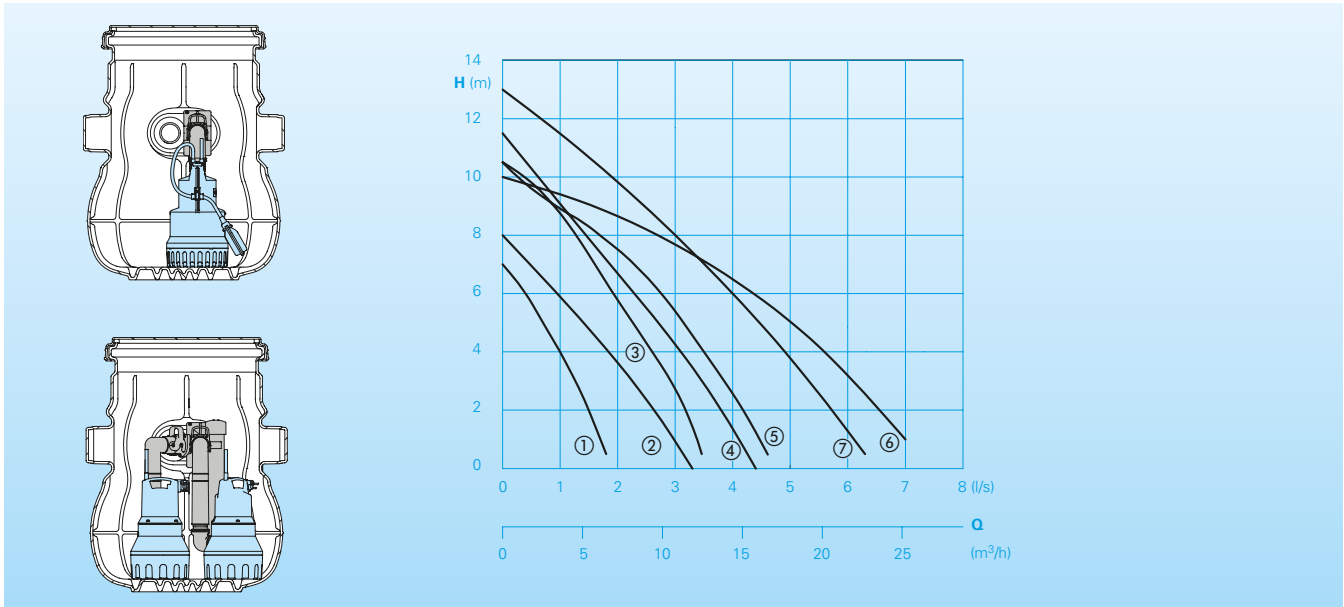

Application

Automatic drainage water disposal below the sewer backflow level, for basement drainage. For connection of wash basin and washing machine. Installation in cellars, basement and bathroom.

DIN EN 12050-2: Design tested and monitored.

Installation: Collection tank for above-floor installation.

Pumped medium: Clear- and drainage water. Max. temperature of pumped medium: 35°C, for brief periods up to 60°C.

Design

Single or double lifting unit with drainage water collection tank consisting of:

Collection tank: Plastic tank, tank volume 120 l, useful volume 66 l, with 3 inlets DN 100. Inlet DN 70 for venting and cable inlet. Odor-proof container lid with quick-release fastener.

Pumps/Motors: One or two single stage drainage water submersible pumps.

Open multi channel impeller, open single channel impeller (TP28M) or Vortex impeller (TP 28 V) free passage 10- 28mm Ø. Fully submersible motor. Insulation class B/F, protection rating IPX8.

Pump selection: The single system (B) is switched on and off by float switch, a WA/DA version is required. The double

Technical data

Curve No.	Type	B	BT	Motor input		Nomial current (A)	Weight (kg)
				P ₁ (kW)	P ₂ (kW)		
①	C140 WA	x	x	0,32	0,17	1,4	4,1
①	CH140 WA	x	x	0,32	0,17	1,4	4,1
②	C250 W(A)	x	x	0,55	0,26	2,5	5,1
②	CH250 W(A)	x	x	0,55	0,26	2,5	5,1
③	C150 WA	x	x	0,75	0,38	3,5	6,0
③	CH150 WA	x	x	0,75	0,38	3,5	6,0
④	C260 W(A)	x	x	0,90	0,48	4,0	6,1
④	CH260 W(A)	x	x	0,90	0,48	4,0	6,1
⑤	TCV 408 WA	x		1,10	0,80	4,9	7,1
⑥	TP28 V W(A)	x		1,10	0,90	5,6	22,0
⑥	TP28 V 11/2 W(A)	x	x	1,10	0,90	5,6	22,0
⑥	TP28 V 11/2 D(A)	x	x	1,10	0,90	2,2	22,0
⑦	TP28 M 10/2 W(A)	x	x	1,00	0,70	4,7	22,0
⑦	TP28 M 10/2 D(A)	x	x	1,00	0,70	1,8	22,0

Rotational speed: 2850 / 2900 rpm/min | **Model W:** 230V/1Ph 50Hz | **Model D:** 400V/3Ph 50Hz

Discharge: G1 1/4 | **Model A:** with automatic float switch HOMA-Nivomatik

system (BT) is switched by control box.

Control box (BT only): Electronic control box PCM for control and monitoring of all important functions. Pneumatic level control with pressure operation. Auto-change over pump after each pump cycle. Operation of both pumps at high flow. In the event of failure automatic change over to the second pump. Motor protection relay. Optical failure alarm. Acoustic alarm by buzzer. Volt free contact for remote signal. Configuration possible via free HOMAApp. Communication between smartphone and control box via Bluetooth.

Materials

Collection tank	Polyethylen
Installation kit	PP GF
Elastomers	NBR

Installation example

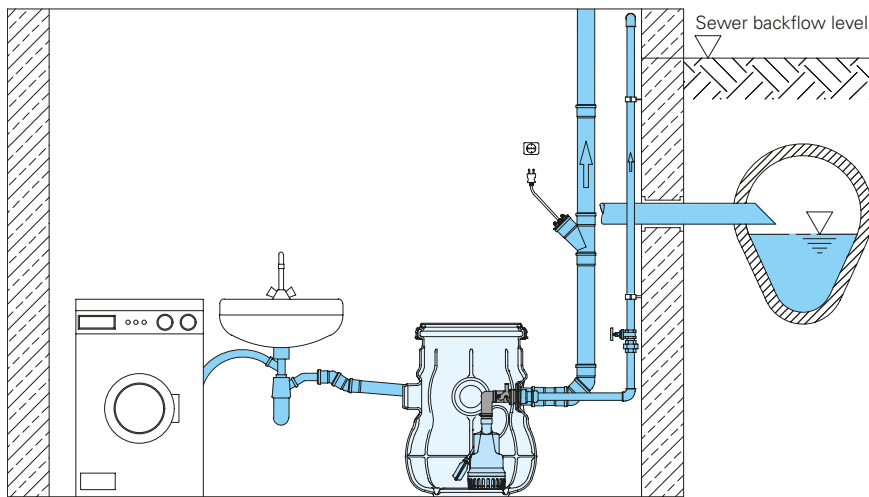

Dimensions (all dimensions in mm)

Collection tank BT100

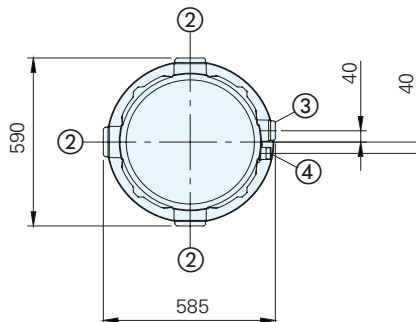
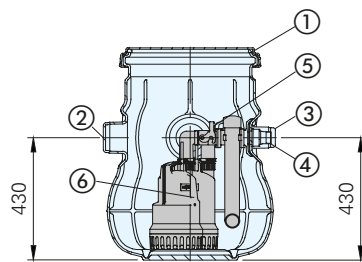
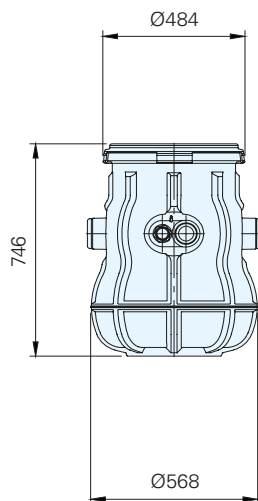

- ① Container lid with quick-release fastener
- ② (3x) Inlet DN100 (ø110)
- ③ Air vent and cable inlet D70 (ø75)
- ④ Connection for pressure pipe G1 1/4
- ⑤ Installation kit with connection lock
- ⑥ Pumps

Scope of supply

Saniquick B100

Plastic collection tank, container lid with quick-release fastener. Rubber cable gland and integrated installation kit.

Part no.: 9804015

Submersible drainage water pumps for Saniquick B100

Pumptype	P ₁ (kW)	Part no.
C140 WA	0,32	9110219
CH140 WA	0,32	9110220
C150 WA	0,75	9110229
CH150 WA	0,75	9110230
C250 WA	0,55	9110365
C260 WA	0,90	9110390
CH250 WA	0,55	9240398
CH260 WA	0,90	9240392
TCV 408 WA	1,10	9500017.01
TP28 VWA	1,1	9500127
TP28 V 11/2 WA	1,1	9211283.02
TP28 V 11/2 DA	1,1	9211293.02
TP28 M 10/2 WA	1,0	9211281.02
TP28 M 10/2 DA	1,0	9211291.02

Saniquick BT100

Plastic collection tank, container lid with quick-release fastener, 2 pumps, rubber cable gland and integrated installation kit, switchgear with mains plug.

Pumptype	Part no.
Saniquick BT100-C140W	9804080
Saniquick BT100-CH140W	9804081
Saniquick BT100-C150W	9804082
Saniquick BT100-CH150W	9804083
Saniquick BT100-C250W	9804084
Saniquick BT100-CH250W	9804085
Saniquick BT100-C260W	9804086
Saniquick BT100-CH260W	9804087
Saniquick BT100-TP28V 11/2W	9804088
Saniquick BT100-TP28V 11/2D	9804089
Saniquick BT100-TP28M 10/2W	9804090
Saniquick BT100-TP28M 10/2D	9804091

Accessories Saniquick B(T)100

Description	Part no.
AL3 alarm unit with level sensor	1586148
ALWS alarm unit with level sensor & washing machine off-switch	1586214
Pipe aerator with filter cartridge DN70/DN100	8001010



We reserve the right to alter our specifications without notice!